

# Nonempirical Study on the Ion-Pair Type Charge-Transfer Complex, Pyridinium Hydrochloride

Frank Jordan

Contribution from the Chemistry Department, Rutgers University,  
The State University of New Jersey, Newark, New Jersey 07102. Received October 5, 1974

**Abstract:** Rigorous ab initio (STO-3G) quantum chemical calculations were performed on various types of pyridinium hydrochloride geometries. The energy-minimized hydrogen-bonded complex is indicated to exist in a single well potential with N-Cl distance of 2.8 Å and N-H distance of 1.4 Å. In accord with the energetics of complex formation, this result indicates that the hydrogen-bonded complex in the gas phase resembles the separated molecules more than the separated ions. The hydrogen-bonding stabilization energy is some 17 kcal/mol. The energy minimized stacked complex places the Cl<sup>-</sup> unsymmetrically, very close to the ortho carbon environment of the ring with distances of the Cl<sup>-</sup> from the ring atoms being much less than the sum of van der Waals radii. The hydrogen-bonded complex is predicted to be much more stable than the stacked one. The changes in charges and orbital energy levels on complex formation are discussed. A rough estimate of the dispersion energies indicates that these complexes are held together primarily by electrostatic interactions, but that the dispersion interactions are much more significant in the stacked complex. In the gas phase (or inert low dielectric solvents) the hydrogen-bonded complex should be the predominant species.

Over the years considerable interest has been generated in the phenomenon of charge-transfer or donor-acceptor complexes.<sup>1</sup> The possible biological significance of such complexes has been explored by various authors.<sup>2</sup>

Presumably, such complexes gain stabilization from, among other sources, the transfer of some finite electron density between two partners in the complex, one partner being the donor the other the acceptor. The complexes may be made up of charged or neutral partners.

Complex formation is very often accompanied by the appearance of a new electronic absorption band.

Since the precise solution geometry and electronic structures of such complexes are very difficult to obtain experimentally and since the solid state structures are undoubtedly subject to nonnearest neighbor influences, it was thought that rigorous quantum chemical studies could provide valuable information concerning the nature of such complexes.

As a starting point in nonempirical calculations of such systems the structure of pyridinium hydrochloride was examined. This structure can be looked at as an ion-pair type charge-transfer complex representative. It offers the advantage of being geometrically fairly rigid (i.e., the pyridine nucleus) and that, in principle, it can form two types of complexes, a hydrogen bonded one and a stacked one. In the latter the chloride ion is located at some position above or below the ring. That the latter type complex can also exist is already well known from the examples of *N*-methylpyridinium iodide type complexes.

In addition, to substantiate the stacked geometry, semiempirical all-valence electron self-consistent-field (SCF) calculations were performed on *N*-methylpyridinium chloride.

The minimal basis set (STO-3G) Gaussian ab initio method<sup>3</sup> was employed in all the pyridinium hydrochloride calculations and the complete neglect of differential overlap (CNDO/2)<sup>4</sup> was used in the *N*-methylpyridinium chloride geometry optimization. The reasons for using both methods are twofold. One is that the ab initio procedure is very expensive and it was extensively applied only to the smaller system. In addition, the CNDO/2 results tend to support the ab initio results since very similar chloride positions are suggested by the different methods for the two stacked complexes.

X-Ray crystallographic data are available on the geometry of pyridinium hydrochloride<sup>5</sup> and on *N*-methylnicotinamide chloride.<sup>6</sup>

The calculations can suggest answers to several questions. The geometry of the complex can be optimized in a state totally devoid of any crystal packing or solvent effects. The relative energies of the two types of complexes can be compared to each other and to the energies of the separated ions or molecules. Finally, the electronic effects of complexation on the resulting charges and energy levels can be observed.

The ab initio method accounts only partially for intermolecular (or interionic) interactions. The total energy can be written as a sum of terms

$$E_{\text{total}} = E_{\text{E1}} + E_{\text{Ex}} + E_{\text{Pol}} + E_{\text{CT}} + E_{\text{Disp}} \quad (1)$$

where the symbols represent electrostatic, exchange repulsion, polarization, charge transfer, and dispersion energies, respectively.<sup>7</sup> The ab initio method is capable of estimating the sum of the first four terms on the right-hand side of eq 1. The sum of  $E_{\text{E1}}$  and  $E_{\text{Ex}}$  is given by the sum of ab initio energies of the separated partners in the complex. The quantity ( $E_{\text{total}} - E_{\text{Disp}}$ ) is given by the energy of the entire complex calculated as a single system. Hence one can estimate the sum of  $E_{\text{Pol}}$  and  $E_{\text{CT}}$  as the difference between the ab initio SCF total energy of the complex and its constituent parts.  $E_{\text{Disp}}$  can be estimated, however, qualitatively from bond refractions and the ionic polarizability of Cl<sup>-</sup> as well as the ionization potentials of the interacting partners. A simple formula for the dispersion energy<sup>8</sup> is

$$E_{\text{Disp}} = \frac{-3(\text{IP}_+)(\text{IP}_{\text{Cl}^-})}{2\text{IP}_+ + \text{IP}_{\text{Cl}^-}} \sum_{i=1}^N \alpha_{i+} \alpha_{\text{Cl}^-} / R_{i+\text{Cl}}^6 \quad (2)$$

where the ionization potentials of the positive and negative ions are used along with bond polarizabilities of the pyridinium ( $\alpha_{i+}$ ) and the ionic polarizability of Cl ion.  $R_{i+\text{Cl}}$  is the distance between the midpoint of the  $i$ th bond in pyridinium and Cl<sup>-</sup>. Bond refraction increments and ionic refraction of 8 cm<sup>3</sup> for Cl<sup>-</sup> were taken from Le Fèvre<sup>9</sup> (molecular units). The ionization potentials used are from this study: 14 eV for pyridinium and 2 eV for the chloride ion (obtained from a 4-31G<sup>10</sup> calculation). Since the dispersion interaction is always a stabilizing one it can be considered as an additive factor to the SCF energy. The dispersion energy was estimated only for the most favorable ab initio geometries.

## Results and Discussion

**The Hydrogen Bonding Interaction Mode. Geometry Optimization.** Figure 1 shows the geometry assumed for the

Table I. Energetics of Systems Related to Pyridinium Hydrochloride<sup>h</sup>

Component	Energy	Total energy
(A) Pyridinium	-244.0626 <sup>a</sup>	
(B) Chloride	-454.4804	
		A + B
		-698.5430
(C) Pyridine	-243.6158	
(D) HCl	-455.1360 <sup>b</sup>	
		C + D
		-698.7518
(E) Hydrogen-bonded ion pair <sup>c</sup>		
Dispersion contribution 2.6 kcal/mole <sup>e</sup>		E
		-698.7794
(F) Slacked ion pair <sup>d</sup>		
Dispersion contribution 4.7 kcal/mole <sup>e</sup>		F
		-698.7100
(G) <i>N</i> -Methylpyridinium <sup>f</sup>	-282.6447	(G) + (B)
		-737.1251
(H) <i>N</i> -Methylpyridinium <sup>f,g</sup> chloride		-737.2854

<sup>a</sup> Minimized at N-H bond distance of  $1.04 \pm 0.001$  Å. <sup>b</sup> Minimized at  $1.30 \pm 0.01$  Å. <sup>c</sup> Bond distances of hydrogen bonded atoms described in text. <sup>d</sup> NH bond distance minimized at  $1.025 \pm 0.025$  Å (very shallow well). <sup>e</sup> Not included in the total energy column. <sup>f</sup> N-C = 1.47 Å, N-C-H and H-C-H angles are tetrahedral. <sup>g</sup> Cl<sup>-</sup> located (Figure 1) at  $x = 1.50, y = 0.50, z = 2.25$ . <sup>h</sup> STO-3G Results in au's 1 au = 627 kcal/mol. .

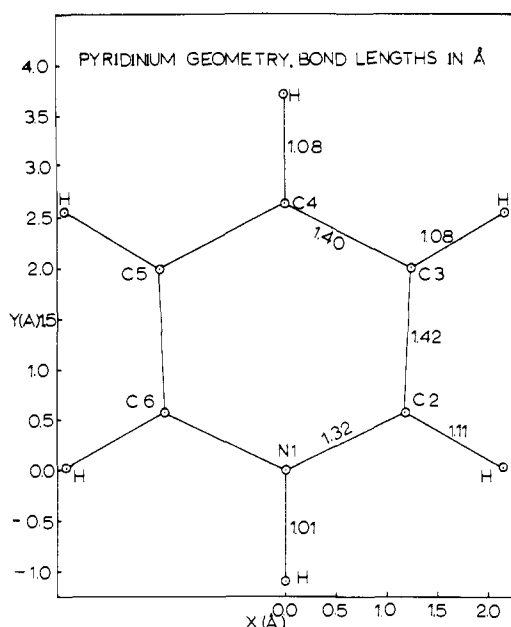

Figure 1. Pyridinium ion geometry assumed in all calculations.

planar pyridinium ring placed in the *X*-*Y* plane. Figure 2 presents the energy minimization results for the different H and Cl positions. Both N-H and N-Cl (hence H-Cl) bond lengths are varied assuming only a colinear approach of Cl<sup>-</sup> in the *X*-*Y* plane. The minimum energy is obtained for N-Cl of  $2.80 \pm 0.05$  Å and N-H of  $1.40 \pm 0.05$  Å. Apparently, for such a short N-Cl distance the hydrogen bonding potential is a single, unsymmetrical well. Such single wells are also found in many other theoretical studies when the distance between the heavy atoms is short.<sup>11</sup>

Table I presents some key energy values. The sum of the separated ion energies (pyridinium + Cl<sup>-</sup>) is -698.5410 au. The sum of the separated molecule energies (pyridine + HCl) is -698.7518 au. Hence the sum of the third and fourth terms in eq 1 is 0.23 au (145 kcal/mol) comparing the most stable hydrogen bonded complex to the ions but is only 0.0276 au (17 kcal/mol) comparing the same complex to the molecular precursors.

Under the conditions of the isolated systems here considered ionization is clearly unfavorable. Yet hydrogen bonding complexation stabilizes the total system by some 17 kcal/mol. The finding that the most favorable geometry for the hydrogen-bonded complex involves stretching the HCl distance from its calculated value of 1.30 Å (experimentally 1.27 Å) to the complexed value of 1.40 Å indicates that the

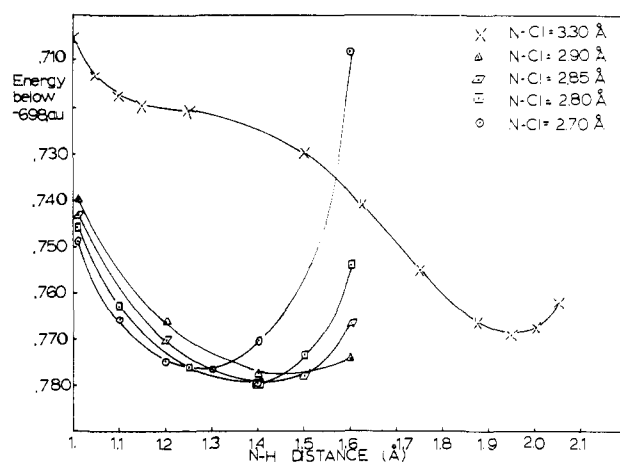

Figure 2. Geometry optimization of the hydrogen-bonded pyridinium hydrochloride complex (STO-3G). Approach of chloride ion is colinear with the N-H bond in the plane of the pyridinium ion.

complex under such "isolated" conditions resembles the molecules (pyridine + HCl) more than the ions (pyridinium + Cl<sup>-</sup>). In the isolated pyridinium ion an N-H distance of 1.04 Å leads to the minimum energy. Compared to this isolated ion the N-H distance is very significantly stretched in the complex.

Precedents similar to this finding, from theoretical calculations, include: (1) Clementi's results on the NH<sub>3</sub>-HCl complex<sup>12</sup> in which an N-Cl of 2.8 Å and an H-Cl distance of 1.62 Å are found (the proton moving much further from Cl in that case than in the present one); and (2) the results of calculations on the HN<sub>3</sub>-HF complex whose energy minimized geometry indicates only a very small stretching of the H-F distance<sup>11</sup> (0.06 Å from the isolated H-F bond distance) upon complex formation. As can also be seen in Figure 2 a significant portion of the stabilization energy of the complex is due to the stretching of the halogen-hydrogen bonds.

At the longer N-Cl distance of 3.30 Å (Figure 2) there appears a hint of a second well near an N-H distance of 1.2 Å. This well is very shallow and at a very high energy. Thermodynamics would clearly dictate the proton position near an N-H distance of 1.95 Å (or H-Cl distance of 1.35 Å). Thus even at such large N-Cl distances there is already significant stretching of the H-Cl bond.

A search of the literature turned up only one related system for which bond distances involving hydrogen were determined rigorously. Mason et al. published the crystal structures of 2-hydroxypyridinium hydrochloride and of

2,6-dihydropyridinium hydrochloride<sup>13</sup> (the study employed both X-ray and neutron diffraction data). The Cl<sup>-</sup> forms a coplanar hydrogen bond (N-Cl length is unspecified for the first system, it is 3.30 Å in the second system) with the N-H. The N-H distance is quoted at 1.06 Å in the first molecule and 0.86 Å in the second one. This is contrary to the theoretical findings in the present work. Apparently, the crystal structure prefers the separated ion like ion pair whereas the isolated system here investigated predicts an ion-pair structure more reminiscent of the separated molecules.

While Rérat<sup>5</sup> did not report the N-H bond distance in pyridinium hydrochloride, the reported crystallographic N-Cl distance of 2.95 Å is not too much longer than the energy minimized value of  $2.80 \pm 0.05$  Å here suggested. Perhaps the reason for the slightly lengthened N-Cl bond in the solid state is due to Cl<sup>-</sup>-Cl<sup>-</sup> repulsions.

There is indication that in solvents of low dielectric constant complexation of pyridine with carboxylic acids may not involve proton transfer. Supposedly, one can picture the proton transfer process as a series of distinct steps.

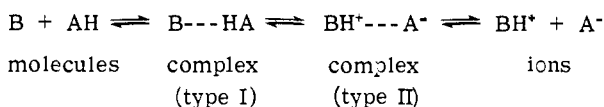

In this relatively simple scheme the type I complex is a hydrogen-bonded complex between the two neutral molecules (pyridine and H-Cl), the type II complex is a hydrogen-bonded intimate ion pair in which the proton is already in a well near the base. Of course, in solution a large variety of solvent-separated ion pairs can intervene between complex II and the separated ions.

Ceska and Grunwald<sup>14</sup> estimated a value of 1.88 for  $K_i$  defined as

$$K_i = [\text{complex II}] / ([\text{B}] + [\text{complex I}]) \quad (3)$$

for pyridine in acetic acid along with a  $K_d$  of  $12 \times 10^{-7}$  where

$$K_d = [\text{BH}^+][\text{A}^-] / [\text{complex II}] \quad (4)$$

Mukherjee and Kelly<sup>15</sup> indicated the existence of a very small dissociation constant of HCl in pure pyridine.

Nelson et al.<sup>16</sup> studied the proton magnetic resonance (PMR) and infrared characteristics of HN<sub>3</sub>, HNCS, and HNCO in CCl<sub>4</sub> solvent. They found no proton transfer to pyridine when the latter was added, although characteristics of hydrogen bonding were in evidence (e.g., weakened N-H stretch in the acids and downfield shift of the acid N-H proton resonance). In addition, it was reported that pyridine in formic acid forms a type I complex.<sup>17</sup> Similar conclusions were drawn from Raman spectroscopic studies<sup>18</sup> on the pyridine-formic acid complex. These authors assigned 8 kcal/mol to the strength of this complex<sup>18</sup> based on in-plane deformation vibrations in pyridine.

Finally, Jenkins and Smith measured the dipole moments of pyridine (2.19 D), acetic acid (1.5 D, monomer), and the pyridine-acetic acid complex (3.73 D) in benzene<sup>19</sup> and suggested that only a type I complex could explain the experimentally found dipole moment of the complex. The calculated dipole moments in the present study are 8.0 D for a type I complex (N-Cl = 2.80 Å, N-H = 1.40 Å) at the energy minimum and 13.1 D for the type II complex (N-Cl = 2.80 Å, N-H = 1.01 Å). At the longer hydrogen bonding distance where there may be two wells the type I complex (N-Cl = 3.30 Å, N-H = 1.95 Å, H-Cl = 1.35 Å) has a dipole moment of 5.17 D whereas the type II complex (N-Cl = 3.30 Å, N-H = 1.25 Å) has a dipole moment of 14.0 D. Clearly the type I complex dipole moment is approaching

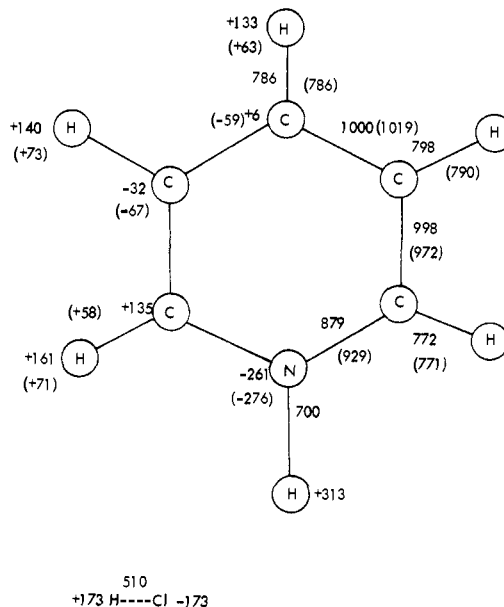

Figure 3. Net atomic and bond overlap populations ( $\times 1000$ ) in pyridinium, pyridine (in parentheses), and H-Cl (1.30 Å bond length) (STO-3G results).

that of the vector sum of pyridine (1.8 D, calculated) and HCl (1.75 D calculated for an H-Cl bond distance of 1.30 Å) individual moments.

It is prudent to use the molecular orbital results with caution. It is also obvious, however, that the experimental evidence in solvents of low dielectric constant does not rule out the preference of the type I complex over the type II complex. Indeed, the lowest energy geometry is somewhere in between the two, though closer to the geometry of the type I complex. While at lengthened N-Cl distance a distinction between the type I and type II complexes is feasible (see Figure 2, N-Cl = 3.30 Å), the energies are considerably above the energy of the lowest energy geometry complex.

Two suggestions can be made. First, the experimental dipole moment in conjunction with theory could be used to determine the solution geometry of the complex since the theory provides dipole moments in substantial agreement with experiment. Second, while the absolute energy differences between the various complexes here reported are subject to error, the theory can complement experimental data (such as reported by Ceska and Grunwald)<sup>14</sup> in attempts to explain stabilization of various types of complexes by solvent.

**Changes in Electron Densities.** In Figure 3 the effects of protonation of pyridine can be discerned. Protonation makes all net charges more positive. The values reported are Mulliken net atomic and bond overlap populations.<sup>20</sup> Upon protonation there is a loss of 0.015 electron from N, 0.077 from C2, 0.035 from C3, and 0.065 from C4 (N-N = 1.01 Å). A loss of 0.090 electron from H(C2), 0.067 from H(C3), and 0.070 from H(C4) is also evident. Interestingly, the nitrogen is predicted to still have a negative charge even in the protonated specie. The absolute charges in pyridine show some alternation (N, -0.261; C2, +0.058; C3, -0.67; C4, -0.59) which is more pronounced upon protonation. PMR evidence indicates a downfield shift with protonation<sup>21</sup> of 0.6 ppm for the C2, 1.0 ppm for the C3, and 1.13 ppm for the C4 hydrogens.

Table II lists changes in electron densities upon hydrogen bonding complexation from either the separated ions or separated molecules. A comparison is made with two hydrogen-bonded structures: A (N-H = 1.01 Å similar to that in

Table II. Changes in Net Atomic and Bond Overlap Populations Upon Complexation ( $\times 1000$ )<sup>a</sup>

Net atomic populations	Compared to ionic precursors <sup>a</sup> Complex structure			Compared to molecular precursors <sup>b</sup> Complex structure		
	H-bond A <sup>c</sup>	H-bond B <sup>d</sup>	Stacked <sup>e</sup>	H-bond A <sup>c</sup>	H-bond B <sup>d</sup>	Stacked <sup>e</sup>
N	+14	+9	+27	+1	-6	+12
C2	+4	+48	-40	-73	-29	-117
C3	+21	+27	+12	-14	-12	-23
C4	+23	+33	+28	-42	-20	-37
C5	+21	+27	+47	-14	-12	+12
C6	+4	+48	+20	-73	-29	-57
H1	-23	+56	+40	-163	-84	-100
H2	+24	+55	-3	-74	-35	-93
H3	+32	+49	+37	-35	-18	-30
H4	+35	+52	+48	-35	-18	-22
H5	+32	+49	+52	-35	-18	-15
H6	+24	+55	+49	-74	-35	-41
C1	-196	-520	-317	+631	+307	+510
Bond overlap populations						
N-C2	+21	+36	-19	-29	-14	-69
C2-C3	-8	-18	-64	+18	+8	-38
C3-C4	+8	+15	+60	-11	-4	+41
N1-H	-218	-494	+10			

<sup>a</sup> A positive change indicates gain of electrons and a negative change an electron loss in going from separated species to complexes. <sup>b</sup> Ionic precursors, pyridinium and chloride ions; molecular precursors, pyridine and HCl in Figure 3. <sup>c</sup> N-Cl = 2.8 Å, N-H = 1.01 Å. <sup>d</sup> N-Cl = 2.8 Å, N-H = 1.40 Å (minimum energy). <sup>e</sup> Minimum energy ab initio configuration C1 at 1.75, 0.25, and 2.25.

isolated pyridinium, N-Cl = 2.80 Å) and B the minimum energy complex (N-H = 1.40 Å, N-Cl = 2.80 Å). This allows for the delineation of the effects of proton movement.

There appears to be gradual shift in charge densities going from the isolated pyridinium ion to complex A to complex B to the isolated molecules.

Formation of structure A from the separated ions involves transfer of 0.2 electron from the chloride ion to the pyridinium ring. The carbon atoms and N absorb less of this change than do the hydrogens. Moving the proton away from the pyridine toward the chloride ion gives more pronounced changes (compare changes in going to complexes A and B). The net effect of this proton movement is to transfer greater electron density from the chloride ion to the ring!

Looking at the electron reorganization from the point of view of the isolated molecules one finds that HCl takes electron density from the ring, the Cl becoming richer and the proton poorer in electron density upon complexation to A and B. While some changes in bond overlap populations also accompany the complexation process, the most dramatic ones are visible along the N-H bond which becomes electron poorer upon the approach of Cl<sup>-</sup>.

In general, the proton movement induces almost as significant a change as the attachment of the chloride ion. Since the conditions under which the present results may apply (low dielectric nonpolar solvent or gas phase) favor formation of the hydrogen-bonded complex from the precursor molecules, the changes quoted for this process are particularly significant. The proton in the donor becomes more positive, but the donor as a whole (HCl) becomes more negative upon hydrogen bonding.

#### The Stacking Interaction Mode. Geometry Optimization.

The Cl<sup>-</sup> ion position was varied in planes parallel to the pyridinium plane (Figure 1) at vertical distances of 1.80, 2.0, 2.25, 2.5, 2.75, 3, and 3.5 Å. Ab initio results on the pyridinium hydrochloride system were obtained. While absolute minimization of the energy was not performed, the Cl<sup>-</sup> coordinates could be ascertained to better than 0.25 Å along any rectangular coordinate axis. The optimization indicates that the incoming Cl<sup>-</sup> when far from the pyridinium prefers a position near the C<sub>2</sub> axis of the positive ion but as

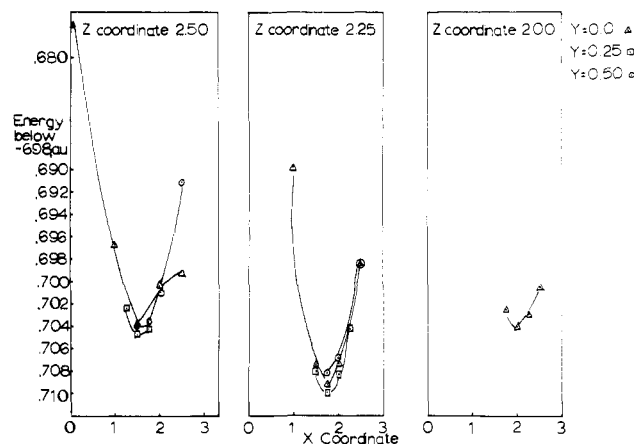

Figure 4. Selected geometry optimization curves for the stacking interaction of chloride ion with pyridinium ion (STO-3G). *x*, *y* and *z* refer to the position of the chloride ion with respect to the pyridinium ring as drawn in Figure 1.

the chloride gets closer quite clearly its preferred position is away from the nitrogen nearer to the C<sub>2</sub> atom (by symmetry this is equivalent to the C<sub>6</sub> atom). Figure 4 shows that energy minimization at vertical distances of 2.0, 2.25, and 2.50 Å. The energy minimized position of Cl<sup>-</sup> is at *x* = 1.75, *y* = 0.25, and *z* = 2.25 Å. This produces the following distances (followed in parentheses by the sums of the van der Waals radii<sup>22</sup> of the atoms which are 1.2 for H, 1.8 for Cl, 1.35 for N(sp<sup>2</sup>), and 1.50 for C(sp<sup>2</sup>)): Cl-N = 2.86 Å (3.15), Cl-H(N) = 3.12 Å (3.0), C<sub>2</sub>-Cl = 2.34 Å (3.30), and Cl-H(C<sub>2</sub>) = 2.30 (3.0). Clearly, the chloride position is predicted to be very close to the C<sub>2</sub> environment. There is to my knowledge no crystallographic evidence for such short contacts. It should be noted that the missing dispersion contribution would shorten these distances further.

First, the position of Cl<sup>-</sup> relative to the C<sub>2</sub> axis is of concern. Rérat's work on pyridinium hydrochloride indicated a Cl<sup>-</sup> position very nearly above the C<sub>2</sub> axis. Lalancette's work on *N*-methylpyridinium iodide indicates the same.<sup>23</sup> Freeman and Bugg's result<sup>6</sup> on *N*-methylnicotinamide chloride and iodide indicates a structure in which the anion is

Table III. Interaction Curve of the Argon–Benzene (STO–3G) Complex

Vertical argon distance, Å	Total energy, au	Vertical argon distance, Å	Total energy, au
Infinite (separated) <sup>a</sup>	-749.113013	4.5	-749.113027
7.0	-749.113024	4.0	-749.113002
6.0	-749.113026	3.5	-749.112684
5.5	-749.113027	3.0	-749.109617
5.0	-749.113027		

<sup>a</sup> Energy of benzene = -227.890106 au and of argon = -521.222907 au.

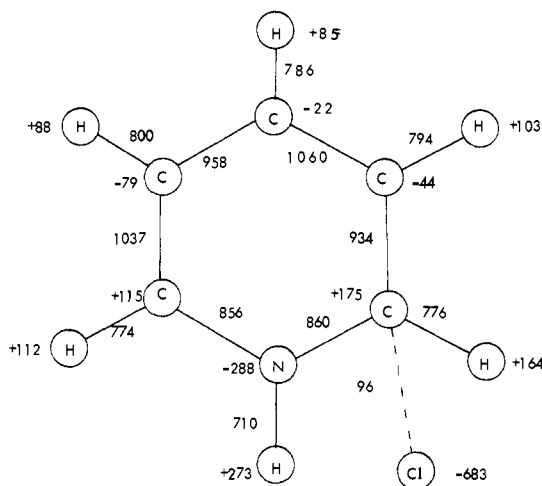

Figure 5. Net atomic and bond overlap population ( $\times 1000$ ) in stacked pyridinium hydrochloride (optimized chloride ion position, STO-3G results).

not above the nitrogen, rather closer to C2 (the side of the ring also containing the carboxamide group). Freeman and Bugg report<sup>6</sup> a 3.24 Å Cl–C2 distance.

One could logically question the performance of the theory. A study was undertaken to see if the STO-3G level of approximation is capable of accounting for intermolecular interactions. Geometry optimization was performed for the interaction of argon with benzene.<sup>24</sup> Argon was allowed to approach benzene from directly above the geometrical center of the ring whose geometry is constructed with all 1.40 Å C–C and 1.08 Å C–H distances and all 120° angles. Table III lists the energy values for the complexation as a function of vertical argon distance. There is a very shallow well between 4.5 and 5.5 Å with a stabilization energy of only 0.01 kcal/mol compared to the separated partners. Again, supposedly the inclusion of favorable dispersion interactions would shorten this distance. Published van der Waals radii<sup>22</sup> (1.92 Å for Ar, 1.85 Å for half-thickness of the aromatic ring) predict a closest distance of approach of 3.8 Å. The calculation can qualitatively predict the shape of intermolecular interaction curves. Incidentally, no evidence of charge transfer from argon to benzene ring is apparent even at 3 Å separation.

The surprisingly short chloride to ring atom distances are probably not an artefact of the calculations since the benzene–argon distance is predicted fairly well. The crystallographic chloride position ( $x = 2, y = 0, z = 2.5$ ) is shown to be within 0.010 au (6 kcal/mol) of the lowest energy configuration. The differences between the present “free space” calculation and the crystal geometry do not preclude such small energy differences. One may note that two chloride ions with -0.7 charge each would give rise to 6 kcal/mol repulsion at a distance of 12 Å from each other.

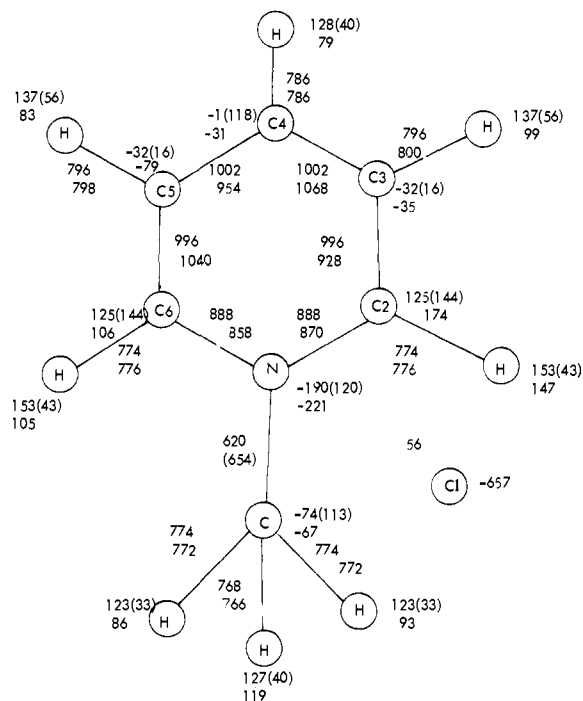

Figure 6. Upper numbers give the net atomic and bond overlap populations (STO-3G) and net charges (CNDO/2 in parentheses) for *N*-methylpyridinium ion. Lower numbers give the corresponding STO-3G figures for the *N*-methylpyridinium chloride, Cl<sup>-</sup>, at 1.5, 0.5, and 2.25.

Since according to the *ab initio* calculations in pyridinium hydrochloride the nitrogen atom retains a negative charge and since an *N*-alkyl group conceivably may change the geometry of the stacked complex, some further calculations were performed on *N*-methylpyridinium ion and *N*-methylpyridinium chloride.

CNDO/2 energy optimization was performed on the chloride ion position in *N*-methylpyridinium chloride in planes parallel to and at various vertical distances from the pyridinium ring. These calculations also place the chloride ion near the C2 environment at all vertical distances examined (2.75, 2.5, 2.25, 2.0, 1.75, and 1.50 Å) but fail to minimize the complex energy even at the 1.5 Å vertical distance.

According to the *ab initio* calculations the stacked pyridinium hydrochloride is some 0.17 au more stable than the separated ions; the *N*-methylpyridinium chloride is 0.16 au more stable than the separated ions (Table I).

**Charge Densities in the Stacked Complex.** The *ab initio* charge densities in the energy optimized stacked pyridinium hydrochloride structures are shown in Figure 5 and compared to the ionic and molecular precursor charge densities in Table II. The charge densities of *N*-methylpyridinium ion (*ab initio* and CNDO/2) and *N*-methylpyridinium chloride complex (*ab initio*) are shown in Figure 6. The dipole moments of *N*-methylpyridinium chloride and stacked pyridinium hydrochloride are very similar for the same position of the chloride ion (8 D for the energy optimized geometry according to the *ab initio* results).

The effect of the methyl group is to decrease the electron density at nitrogen compared to a hydrogen substituent. Attachment of chloride ion transfers 0.35 electron to the pyridinium ring in the energy optimized geometry. There is one very interesting feature of complexation. While the charges at most atoms become less positive, at C2 they become more positive thus enhancing the electrostatic interaction with the chloride ion.

**On the Ordering of Energy Levels in Different Ion Pairs.**

Table IV. Orbital Energies of Pyridine, Pyridinium, and Chloride Ions and of the Hydrogen-Bonded and Stacked Complexes<sup>a</sup>

Pyridine <sup>b</sup>	Pyridinium	Chloride	Hydrogen-bonded complexes		Stacked complex <sup>e</sup>	Notes
			A <sup>c</sup>	B <sup>d</sup>		
-15.3283 (1a <sub>1</sub> )	-15.7504	-102.9964	-103.2944	-103.5113	-103.3534	Cl1s
-11.0797 (1b <sub>2</sub> )	-11.3625		-15.5388	-15.4282	-15.5238	N1s
-11.0797 (2a <sub>1</sub> )	-11.3625		-11.2025	-11.1417	-11.1841	Cl1s
-11.0461 (3a <sub>1</sub> )	-11.2922		-11.2025	-11.1417	-11.1656	Cl1s
-11.0436 (2b <sub>2</sub> )	-11.2799		-11.1463	-11.0974	-11.0912	Cl1s
-11.0436 (4a <sub>1</sub> )	-11.2799		-11.1324	-11.0902	-11.0771	Cl1s
			-11.1324	-11.0902	-11.0732	Cl1s
		-9.7277	-10.0128	-10.2101	-10.0683	Cl
		-7.1682	-7.4547	-7.6536	-7.5102	Cl
		-7.1682	-7.4527	-7.6491	-7.5080	Cl
		-7.1682	-7.4527	-7.6491	-7.5080	Cl
-1.1996 (5a <sub>1</sub> )	-1.5283		-1.3471	-1.2699	-1.3250	
-1.0202 (6a <sub>1</sub> )	-1.2742		-1.1258	-1.0732	-1.0801	
-0.9773 (3b <sub>2</sub> )	-1.2336		-1.0767	-1.0281	-1.0432	
-0.7970 (7a <sub>1</sub> )	-1.0603		-0.9031	-0.9125	-0.8715	
-0.7894 (4b <sub>2</sub> )	-1.0556		-0.9018	-0.8513	-0.8681	
-0.6660 (8a <sub>1</sub> )	-0.9659		-0.8142	-0.8377	-0.7972	
-0.6094 (9a <sub>1</sub> )	-0.8614		-0.7463	-0.7223	-0.7648	
-0.5965 (5b <sub>2</sub> )	-0.8417		-0.7063	-0.6529	-0.6715	
-0.5482 (6b <sub>2</sub> )	-0.8155		-0.6911	-0.6511	-0.6599	
-0.4954 (10a <sub>1</sub> )	-0.7949 (b <sub>1</sub> ,π)		-0.6615	-0.5948	-0.6292	
-0.4909 (1b <sub>1</sub> ,π)	-0.7837		-0.6363	-0.5836	-0.5999	
-0.4763 (7b <sub>2</sub> )	-0.7061		-0.6163 (b <sub>1</sub> ,π)	-0.5518 (b <sub>1</sub> ,π)	-0.5946	
-0.3198 (2b <sub>1</sub> ,π)	-0.6691		-0.5633	-0.5220	-0.5205	
-0.3045 (11a <sub>1</sub> )	-0.5795 (b <sub>1</sub> ,π)		-0.5199	-0.4736	-0.4852	
-0.2926 (1a <sub>2</sub> ,π)	-0.5240 (a <sub>2</sub> ,π)		-0.4326 (b <sub>1</sub> ,π)	-0.3785 (b <sub>1</sub> ,π)	-0.4000 (π)	
		-0.5073	-0.3768 (a <sub>2</sub> ,π)	-0.3368 (a <sub>2</sub> ,π)	-0.3517 (π)	
		+0.0618	-0.1869 (n)	-0.3078	-0.2120 (n)	
		+0.0618	-0.1752 (n)	-0.2987 (n)	-0.2107 (n)	
		+0.0618	-0.1743 (n)	-0.2980 (n)	-0.1694 (n,π)	
0.2385 (a <sub>2</sub> ,π*)	-0.0248 (b <sub>1</sub> ,π*)		0.1376 (b <sub>1</sub> ,π*)	0.1944 (a <sub>2</sub> ,π*)	0.1744	
0.2622 (b <sub>1</sub> ,π*)	0.0107 (a <sub>2</sub> ,π*)		0.1553 (a <sub>2</sub> ,π*)	0.1990 (b <sub>1</sub> ,π*)	0.2154	
0.4867 (π*)	0.2356		0.3829 (π*)	0.4320	0.4218	

<sup>a</sup> For ease of comparison the same pyridine ring geometry (Figure 1) is employed in all reported structures; all energies reported in au's (1 au = 627 kcal/mol). <sup>b</sup> Symmetry assignments directly comparable to published data (ref 27). <sup>c</sup> N-Cl = 2.80 Å, N-H = 1.01 Å. <sup>d</sup> N-Cl = 2.80 Å, N-H = 1.40 Å (lowest energy hydrogen-bonded structure). <sup>e</sup> Lowest energy stacked structure, Cl<sup>-</sup> at  $x = 1.50$  and  $y = 0.25$  (see Figure 1).

Table IV describes the changes in energy levels in pyridinium and chloride ions upon pair formation as well as a comparison with the levels in pyridine. Considerable interaction in *all levels* is obvious. Comparison of separated ions with the hydrogen-bonded ion pair is made easier by the clearcut  $\sigma$ - $\pi$  separation allowing for direct comparison of  $\pi$  levels for example. Upon ion-pair formation there is significant destabilization of the  $\pi$  type molecular orbital levels. This implies that  $\pi \rightarrow \pi^*$  electronic transitions should shift to longer wavelength upon formation of the ion pair, that is as the two ions approach each other. Also of some interest is the lowering of the chloride levels to strongly bonding energies upon ion-pair formation. It should be remarked that extended basis set calculations (4-31G) on chloride ion place the triply degenerate (3p) lone pair orbitals slightly negative (-0.06 au) instead of the +0.06 quoted in Table IV. Kosower many years ago reported the formation of a new "charge-transfer band" in solutions of *N*-methylpyridinium iodide.<sup>25</sup> The maximum of this band shifts to longer wavelength as the solvent dielectric constant is decreased.

More recently Poziomek and coworkers have reported their results concerning the origins of the charge-transfer bands.<sup>26</sup> In solvents of low dielectric constant (such as CHCl<sub>3</sub> and CH<sub>2</sub>Cl<sub>2</sub>) two charge-transfer bands are observed.<sup>26b</sup> Based on experimental evidence supported by theoretical (extended Hückel) calculations,<sup>26c</sup> it was suggested that the two bands correspond to electronic transitions from I<sup>-</sup> to the two lowest energy vacant pyridinium orbitals. For different substituents, a linear correlation was found between the experimental energy difference of the two charge-transfer bands and the difference in energies of the two lowest energy vacant orbitals.

Table IV lists the orbital energies of pyridine (geometry from the pyridinium ion), separated pyridinium and chloride ions, the hydrogen bonded complexes A and B, and the stacked pyridinium hydrochloride complex. A comparison of the pyridine orbital energies (symmetry assignments based on C<sub>2v</sub> point group) with literature values is available.<sup>27</sup> A comparison with the other species is interesting. First of all, bringing together the pyridinium and chloride ions destabilizes the orbital energies of the former and stabilizes the energies of the latter. Second, Poziomek et al.'s suggestion<sup>26c</sup> is supported by the pyridinium results; i.e., the energy difference between the two most stable vacant orbitals (b<sub>1</sub> at -0.0248 au and a<sub>2</sub> at 0.0107 au) is 0.0355 au or 22.4 kcal/mol, in pyridinium hydrochloride, close to the experimental 21.3 kcal/mol difference between the two charge-transfer bands in the *N*-methylpyridinium iodide (in CH<sub>2</sub>Cl<sub>2</sub>). The corresponding difference in *N*-methylpyridinium is 0.032 au or 20 kcal/mol. Third, some effects of the ionic interaction are noteworthy. The  $\pi$  levels are strongly perturbed by complexation both by hydrogen bonding and by stacking. What is particularly striking though is that for the same N-H distance the stacking interaction gives more destabilization of the  $\pi$  orbitals than does the hydrogen bonding one. In addition, in the hydrogen-bonding interaction mode the N-H bond distance has a very significant effect on the energy of the  $\pi$  orbitals (the longer the distance the less stable the  $\pi$ -orbital energies become). Again, this just emphasizes what was stated before, that N-H stretching distorts the energies toward the separated molecule values. The results on pyridine imply that charge transfer to the vacant orbitals of this system should result in more closely spaced bands whose symmetry ordering is opposite

to that of the pyridinium system. Supposedly some of the results here presented can be tested experimentally. Rigorous calculation of the electronic spectral properties of such systems based on ab initio wave functions have not yet been reported.

**Critical Evaluation of the Results and Conclusions.** As Table II indicates the STO-3G method is capable of predicting bond distances quantitatively. The equilibrium bond distance of H-Cl is calculated at  $1.30 \text{ \AA} \pm 0.01 \text{ \AA}$ , compared to the experimental gas phase value of  $1.274 \text{ \AA}$ .<sup>28</sup> In the isolated pyridinium ring the N-H distance is energy optimized at  $1.02 \text{ \AA}$ .

The absolute energy differences are undoubtedly in error. The experimental energy difference between pyridine and pyridinium in the gas phase is defined as the proton affinity and is quoted at 225 kcal/mol.<sup>29</sup> The ab initio STO-3G result is 275 kcal/mol, some 20% higher than the experimental value. This quantity can be improved upon. The 4-31G level of approximation predicts 235 kcal/mol (unpublished from this laboratory) for the pyridine proton affinity, a value within 4% of experiment!

The predictions of this study are expected to be correct, certainly qualitatively.

The hydrogen-bonded geometry of pyridinium hydrochloride is more stable than the stacked complex and the former complex resembles the geometry of the isolated pyridine and HCl molecules more than the isolated ions. The hydrogen-bonded complex has a slightly stretched H-Cl bond and is calculated to have 17 kcal/mol stabilization compared to the isolated molecules.

In the stacked geometry the halide ion is predicted to be nearer to the C2 atom than to the nitrogen atom and a rather short ( $2.50 \pm 0.1 \text{ \AA}$ ) C-Cl "nonbonding" distance is apparent, with a positive 0.060 overlap population between the two.

Finally, one can compare the "classical" electrostatic interaction in the two types of ion pairs based on net atomic populations of pyridinium hydrochlorides (energy =  $q_1q_2/\epsilon r_{12}$ ). Assuming a dielectric constant,  $\epsilon$ , of unity, in the hydrogen bonded system the interaction energy is -32 kcal/mol, in the stacked one it is -48 kcal/mol (for energy optimized atomic configurations).

In either complex as well as in *N*-methylpyridinium chloride it is important to note that the two ions never carry integral charges at distances of  $3.5 \text{ \AA}$  or less. The assumption of unit charges in contact or intimate ion pairs is probably not justified. The calculations suggest that the geometry of

such complexes in the gas state or in low dielectric medium may be very different from the crystallographic one.

**Acknowledgment.** I want to thank the Center of Computer and Information Services at Rutgers University for the generous donation of computer time for this project and Dr. Roger Lalancette for his discussions concerning his X-ray results on *N*-methylpyridinium iodide.

## References and Notes

- (1) R. S. Mulliken and W. B. Person, "Molecular Complexes", Wiley, New York, N.Y., 1969; R. Foster, "Organic Charge Transfer Complexes", Academic Press, New York, N.Y., 1969.
- (2) See several articles in B. Pullman, Ed., "Molecular Associations in Biology", Academic Press, New York, N.Y., 1968.
- (3) W. J. Hehre, R. F. Stewart, and J. A. Pople, *J. Chem. Phys.*, **51**, 2657 (1969); Quantum Chemistry Program Exchange No. 236.
- (4) G. A. Segal and J. A. Pople, *J. Chem. Phys.*, **44**, 3289 (1966), Quantum Chemistry Program Exchange No. 141.
- (5) C. Rerat, *Acta Crystallogr.*, **15**, 427 (1962).
- (6) G. R. Freeman and C. F. Bugg, *Acta Crystallogr., Sect. B*, **30**, 431 (1974).
- (7) P. A. Kollman and L. C. Allen, *Chem. Rev.*, **72**, 283 (1972); P. A. Kollman and L. C. Allen, *Theor. Chim. Acta.*, **18**, 399 (1970).
- (8) F. Jordan and H. D. Sostman, *J. Am. Chem. Soc.*, **95**, 6554 (1973).
- (9) R. J. W. Le Févre, *Adv. Phys. Org. Chem.*, **3**, 1 (1965).
- (10) (a) W. J. Hehre, R. Ditchfield, L. Radom, and J. A. Pople, *J. Am. Chem. Soc.*, **92**, 4796 (1970); (b) R. Ditchfield, W. J. Hehre, and J. A. Pople, *J. Chem. Phys.*, **54**, 724 (1971).
- (11) P. A. Kollman and L. C. Allen, *J. Am. Chem. Soc.*, **93**, 4991 (1971), and references therein.
- (12) E. Clementi, *J. Chem. Phys.*, **46**, 3851 (1967), and subsequent articles.
- (13) S. A. Mason, J. C. B. White, and A. Woodlock, *Tetrahedron Lett.*, 5219 (1969).
- (14) G. W. Ceska and E. Grunwald, *J. Am. Chem. Soc.*, **89**, 1371 (1967).
- (15) L. M. Mukherjee and J. J. Kelly, *J. Phys. Chem.*, **71**, 2348 (1967).
- (16) J. Neilson, R. Spratt, and S. M. Neilson, *J. Chem. Soc. A*, 583 (1970).
- (17) A. Stratula-Ciobanu and E. Ruxandra, *Chem. Abstr.*, **75**, 122892 m (1971).
- (18) L. Singurelu and P. A. Bazhulin, *Vestn. Mosk. Univ., Fiz., Astronomiya*, **22**, 11-15 (1967); cf. *Chem. Abstr.* **66**, 120547t (1968).
- (19) J. O. Jenkins and J. W. Smith, *J. Chem. Soc. B*, 1538 (1970).
- (20) R. S. Mulliken, *J. Chem. Phys.*, **23**, 1833 (1955).
- (21) J. B. Merry and J. H. Goldstein, *J. Am. Chem. Soc.*, **88**, 5560 (1966).
- (22) F. A. Cotton and G. Wilkinson, "Advanced Inorganic Chemistry", 3rd ed, Interscience, New York, N.Y., 1972, pp 120.
- (23) R. A. Lalancette, unpublished, personal communication.
- (24) I want to thank an anonymous referee for suggesting this calculation. While this calculation shows that the method is qualitatively satisfactory for the prediction of interaction energies between neutrals, obviously it does not necessarily apply to the interaction of ions.
- (25) E. M. Kosower, *J. Am. Chem. Soc.*, **77**, 3883 (1955), and subsequent papers.
- (26) (a) R. A. Mackay and E. J. Poziomek, *J. Am. Chem. Soc.*, **92**, 2432 (1970); (b) R. A. Mackey, J. R. Randolph, and E. J. Poziomek, *ibid.*, **93**, 5026 (1971); (c) R. A. Mackay and E. J. Poziomek, *ibid.*, **94**, 4167 (1972).
- (27) D. W. Genson and R. E. Christofferson, *J. Am. Chem. Soc.*, **94**, 6904 (1972).
- (28) L. E. Sutton, *Chem. Soc., Spec. Publ.*, **No. 18**, (1965).
- (29) E. M. Arnett, *Acc. Chem. Res.*, **6**, 404 (1973).